



晶采光電科技股份有限公司  
AMPIRE CO., LTD.

## SPECIFICATIONS FOR LCD MODULE

<b>CUSTOMER</b>	
<b>CUSTOMER PART NO.</b>	
<b>AMPIRE PART NO.</b>	<b>AM-800480AZTMQW-05H</b>
<b>APPROVED BY</b>	
<b>DATE</b>	

- Approved For Specifications  
 Approved For Specifications & Sample

**AMPIRE CO., LTD.**  
**Building A., 4F., No.116, Sec. 1, Sintai 5th Rd., Xizhi Dist,**  
**New Taipei City 221, Taiwan (R.O.C.)**  
新北市汐止區新台五路一段 116 號 4 樓(東方科學園區 A 棟)  
TEL:886-2-26967269 , FAX:886-2-26967196 or 26967270

APPROVED BY	CHECKED BY	ORGANIZED BY

## RECORD OF REVISION

Revision Date	Page	Contents	Editor
2016/10/03	-	New Release	Lawlite
2018/07/25	6	Characteristics of LVDS Receiver	Lawlite
2018/12/06	7	Add LED driver power input	Lawlite
	9	Update interface	
	16.17	Update drawing	

## 1. FEATURES

- (1) Construction : a-Si TFT-LCD with driving system, White LED Backlight
- (2) LCD type : Transmissive , Normally White
- (3) Number of the Colors : 262K colors (R,G,B 6 bit digital each)
- (4) LVDS Interface 20 pin.
- (5) LCD Power Supply Voltage: 3.3V single power input, built-in power supply circuit.
- (6) ROHS compliant.
- (7) PCB : 800480L-A0. Built-in LED Driver

## 2. PHYSICAL SPECIFICATIONS

Item	Specifications	unit
Display size (diagonal)	5.0	inch
Resolution	800 (W) x RGB x 480 (H)	dot
Display area	108.0 (W) x 64.8 (H)	mm
Pixel pitch	0.135 (W) x 0.135 (H)	mm
Overall dimension	118.5(W) x 77.1(H) x7.11(D)	mm
Color configuration	R.G.B Vertical stripe	
View Direction (Gray Inversion)	6 o'clock	

## 3. ABSOLUTE MAXIMUM RATINGS

Item	Symbol	Min.	Max.	Unit	Note
Power Supply for logic	VCC	-0.5	5.0	V	
Input Signal Voltage	VI	-0.5	VCC + 0.5	V	
Operating Temperature	Top	-20	70	°C	(1)
Storage Temperature	Tstg	-30	80	°C	

Note (1): Background color changes slightly depending on ambient temperature.  
This phenomenon is reversible.

#### 4. OPTICAL CHARACTERISTICS

Item		Symbol	Condition	Min.	Typ.	Max.	Unit	Note
Viewing Angle	Front	$\theta f$	$CR \geq 10$	60	70	--	deg.	(1)(2)(3)
	Back	$\theta b$		50	60	--		
	Left	$\theta l$		65	75	--		
	Right	$\theta r$		65	75	--		
Contrast ratio		CR	$\Theta = \Phi = 0^\circ$	480	600	--	--	(1)(3)
Response Time		$T_r$	$\Theta = \Phi = 0^\circ$	--	2	4	ms	(1)(4)
		$T_f$		--	6	12	ms	(1)(4)
Color chromaticity	Red	Rx	$\Theta = \Phi = 0^\circ$	0.576	0.626	0.676	--	(1)
		Ry		0.296	0.346	0.396		
	Green	Gx		0.272	0.322	0.372		
		Gy		0.502	0.552	0.602		
	Blue	Bx		0.099	0.149	0.199		
		By		0.133	0.183	0.233		
	White	Wx		0.260	0.310	0.360		
		Wy		0.299	0.349	0.399		
Luminance (ILED=240mA)		L	$\Theta = \Phi = 0^\circ$	400	500	--	cd/m <sup>2</sup>	(1)(5)
Luminance Uniformity		$\Delta L$	$\Theta = \Phi = 0^\circ$	70	-	-	%	(1)(5)(6)

Note 1:  $T_a = 25^\circ\text{C}$ . To be measured on the center area of panel after 10 minutes operation.

Note 2: Definition of Viewing Angle

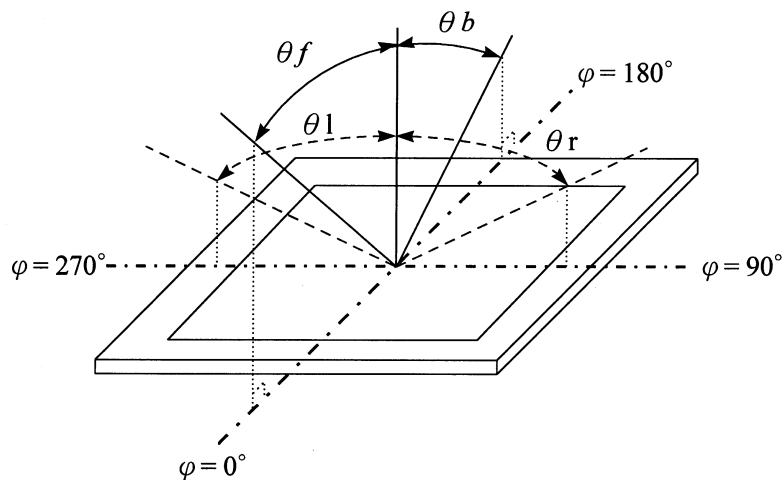

Note 3: Definition of contrast ratio:

Contrast ratio is calculated with the following formula.

$$\text{Contrast ratio(CR)} = \frac{\text{Photo detector output when LCD is at "White" state}}{\text{Photo detector Output when LCD is at "Black" state}}$$

Note 4: Definition of response time:

The output signals of photo detector are measured when the input signals are changed from "black" to "white"(falling time) and from "white" to "black" (rising time) respectively. The response time is defined as the time interval between the 10% and 90% of amplitudes. Refer to figure as below.

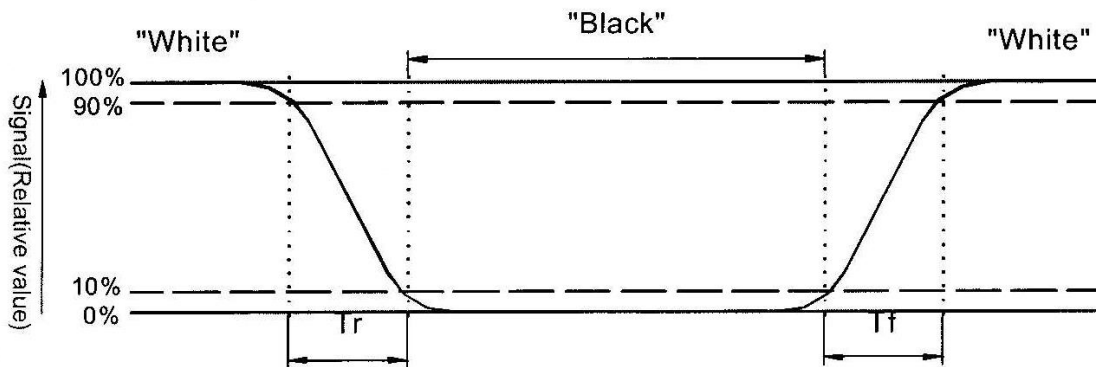

Note 5 : Luminance is measured at point 5 of the display.

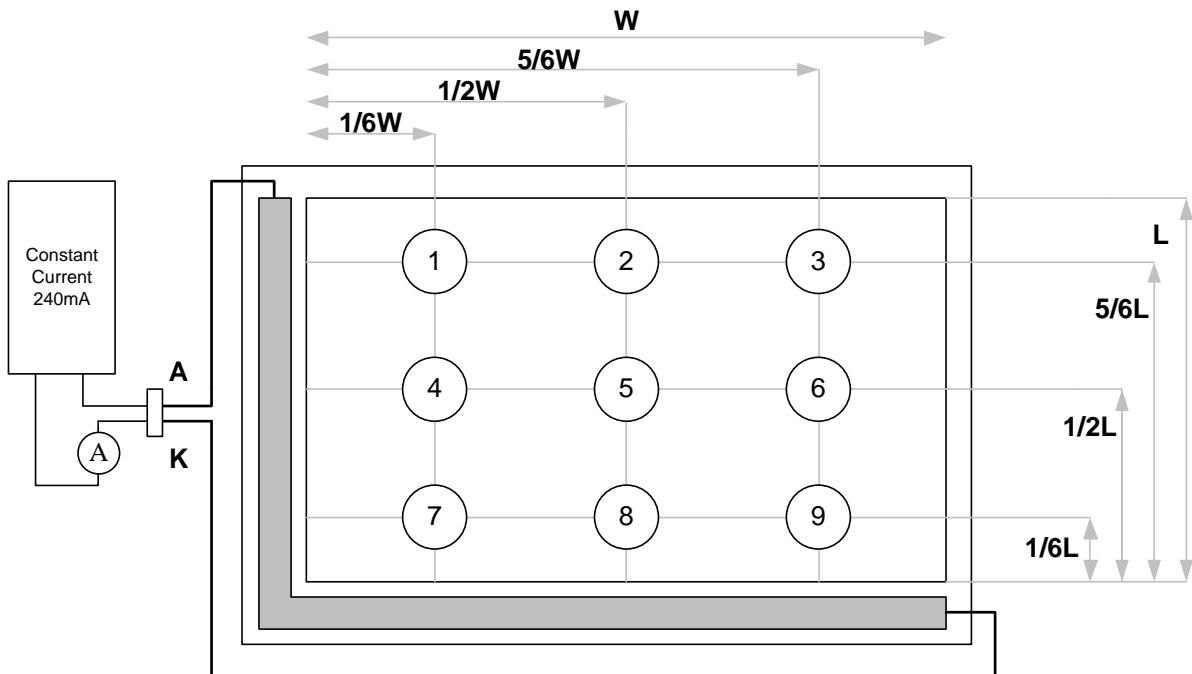

Note 6 : Definition of Luminance Uniformity

$$\Delta L = [ L(\text{min.}) \text{ of 9 points} / L(\text{max.}) \text{ of 9 points}] \times 100\%$$

## 5. ELECTRICAL CHARACTERISTICS

### 5.1 Switching Characteristics of LVDS Receiver

Item	Symbol	Min.	Typ.	Max.	Unit	Condition
Differential Input High Threshold	VTH	--	--	100	mV	VCM=1.2V
Differential Input Low Threshold	VTL	-100	--	--	mV	
Input current	IIN	-10	--	+10	uA	
Differential input Voltage	VID	0.2	--	0.6	V	
Common Mode Voltage Offset	VCM	$\frac{ VID }{2}$	1.25	$2.4 - \frac{ VID }{2}$	V	

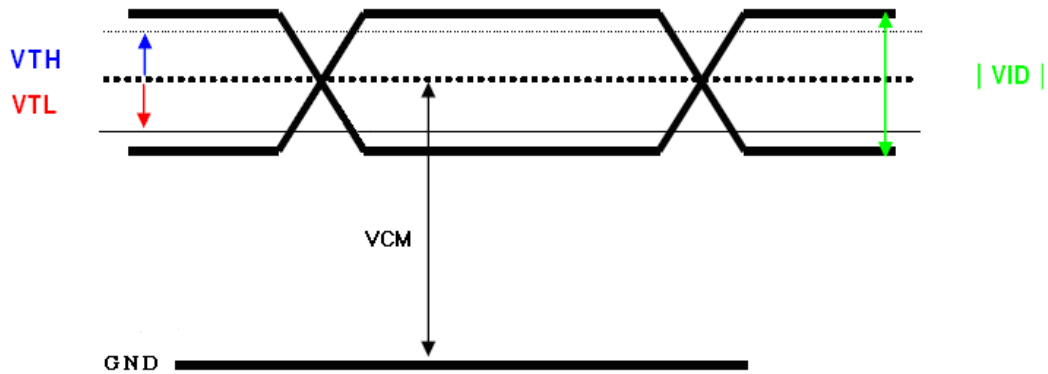

## 5.2 Electrical characteristic of LED Back-light

### 5-2-1 LED DRIVER POWER INPUT

ITEM	SYMBOL	MIN	TYP	MAX	UNIT	CONDITION
Power Supply Voltage For LED	VLED	4.5	5	5.5	V	
Power Supply Current For LED	ILED	-	320	420	mA	VLED=5V ADJ=3.3V
ADJ signal frequency	fPWM	200	--	1K	Hz	
ADJ signal logic level High	VIH	1.2	3.3	5.0	V	
ADJ signal logic level Low	VIL	-	-	0.5	V	

### 5-2-2 LED BACK\_LIGHT UNIT

(For design reference only, user does not need to supply this power)

Item	Symbol	Min.	Typ.	Max.	Unit	Note
LED Forward Current	IF	--	140	--	mA	Ta=25°C , A1+A2 total current
LED Forward Voltage	VF	8.4	9.0	10.2	V	IF=140mA, Ta=25°C
LED life time			30,000	-	Hr	IF=140mA, Ta=25°C

Note 1: Ta means ambient temperature of TFT-LCD module.

Note 2: If the module is driven by high current or at high ambient temperature & humidity condition. The operating life will be reduced.

Note 3: The constant current source is needed for LED back-light driving.

Note 4: Operating life means brightness goes down to 50% minimum brightness. LED life time is estimated data. Ta=25°C

Note 5: the structure of LED B/L shows as below.

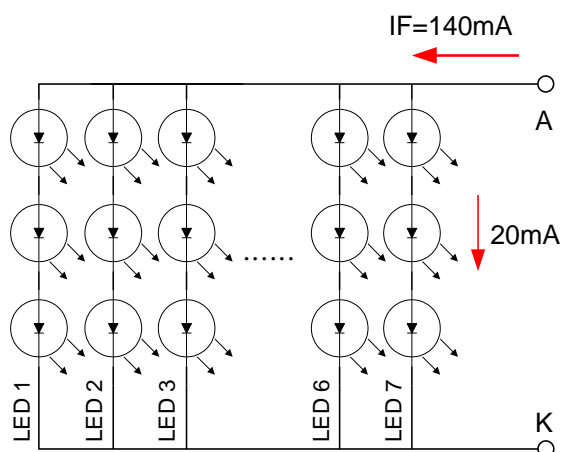

Note 6: When LCM is operated over 60°C ambient temperature, the  $I_{LED}$  of the LED back-light should be adjusted to 105mA max

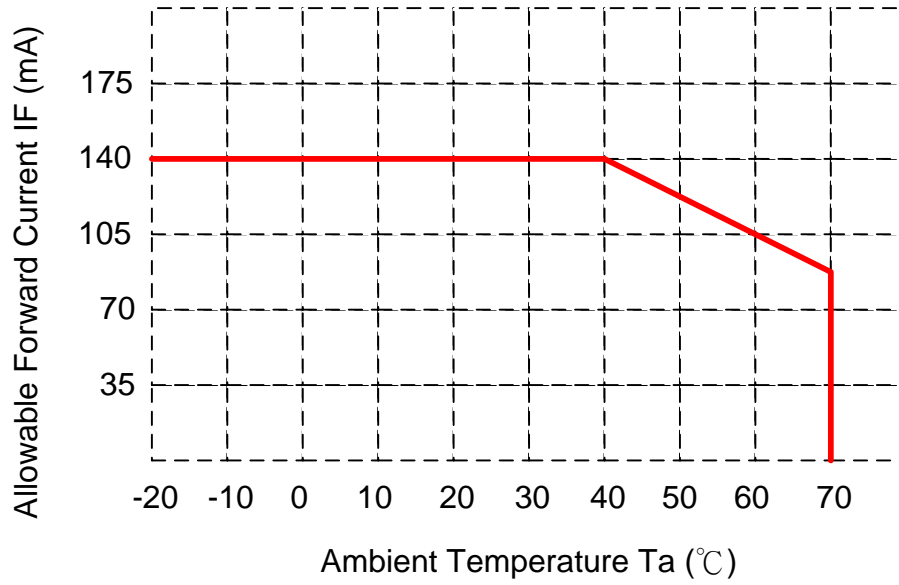



# INTERFACE PIN ASSIGNMENT

TFT\_LCD: CN3 P1.0x20PIN CP100-S20G-H16 / DF-19G-20P-1H or Equivalent

Pin No.	Symbol	Function
1	VDD	POWER SUPPLY:3.3V
2	VDD	POWER SUPPLY:3.3V
3	GND	Power Ground
4	GND	Power Ground
5	IN0-	Transmission Data of Pixels
6	IN0+	Transmission Data of Pixels
7	GND	Power Ground
8	IN1-	Transmission Data of Pixels 1
9	IN1+	Transmission Data of Pixels 1
10	GND	Power Ground
11	IN2-	Transmission Data of Pixels 2
12	IN2+	Transmission Data of Pixels 2
13	GND	Power Ground
14	CLK-	Sampling Clock
15	CLK+	Sampling Clock
16	GND	Power Ground
17	VLED	POWER SUPPLY for Backlight : <b>5V</b>
18	VLED	POWER SUPPLY for Backlight : <b>5V</b>
19	GND	Power Ground
20	ADJ	LED PWM SIGNAL

**Note1:** ADJ is PWM signal input. It is for brightness control.

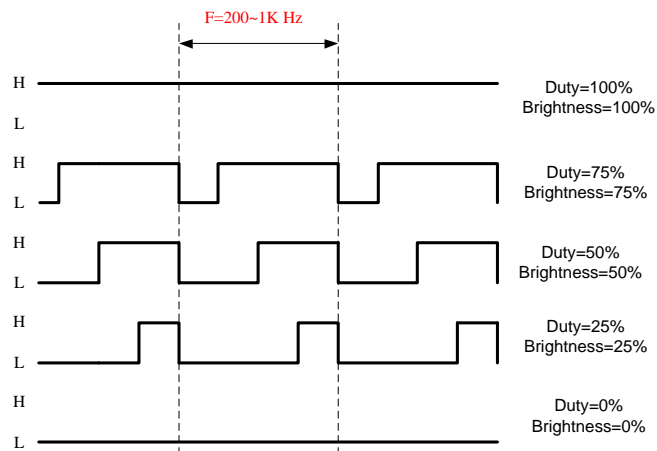

## 6. INTERFACE TIMING

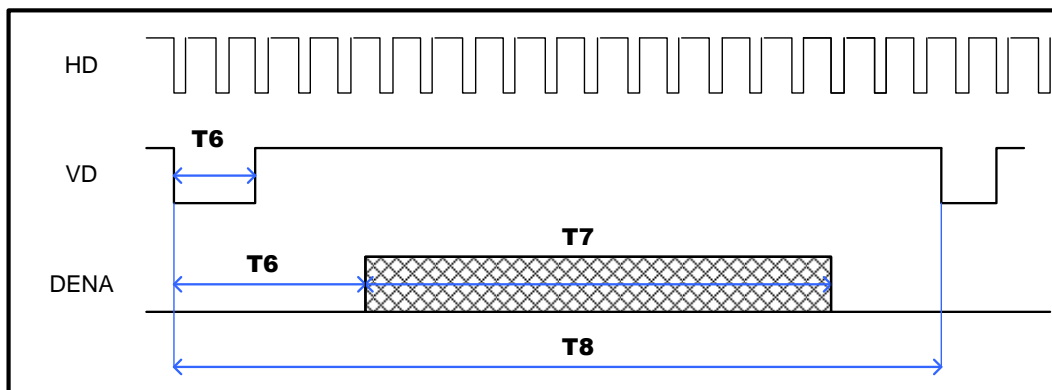
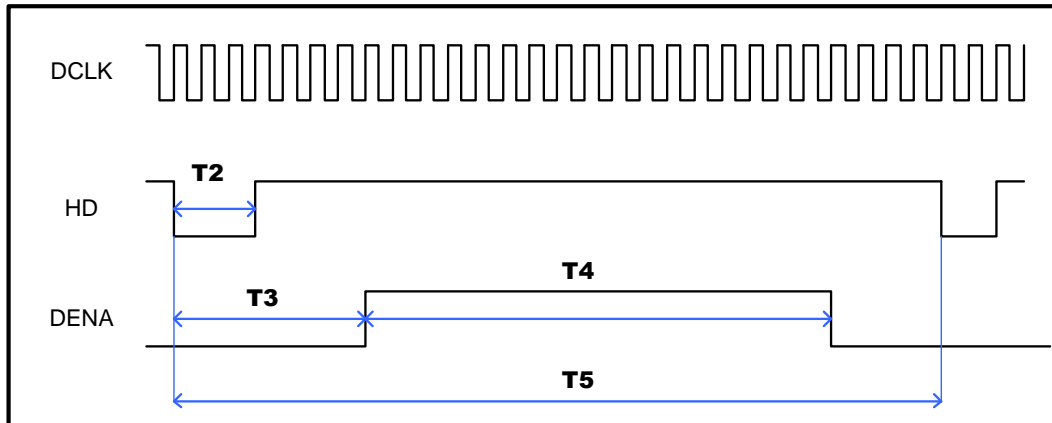
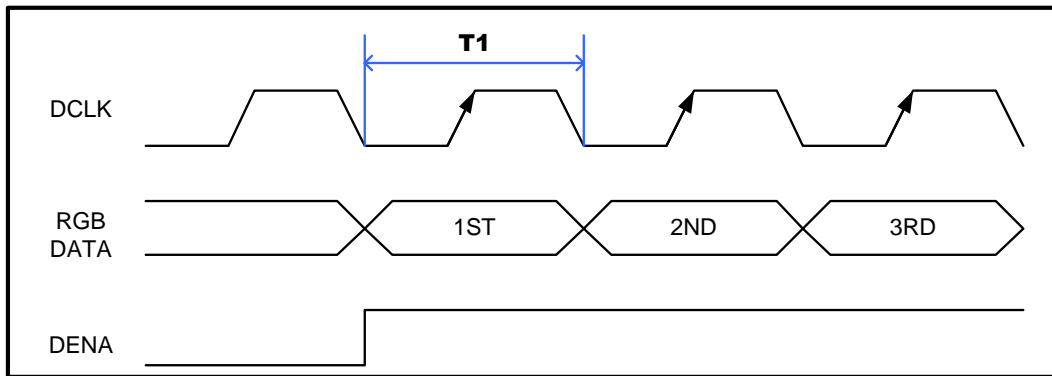

ITEM	SYMBOL	MIN	TYP	MAX	UNIT
Clock Frequency	1/T1	--	33.3	50	MHz
HSYNC Plus Wide	T2	4	48	64	clocks
HSYNC to DE	T3	88	88	88	Clocks
Horizontal Display Period	T4	--	800	--	Clocks
Horizontal total Period	T5	908	928	1010	Clocks
VSYNC Plus Wide	T2	1	3	31	Lines
VSYNC to DE	T6	32	32	32	Lines
Vertical Display Period	T7	--	480	--	Lines
Vertical total Period	T8	515	525	--	Lines

## Power On/Off Sequence

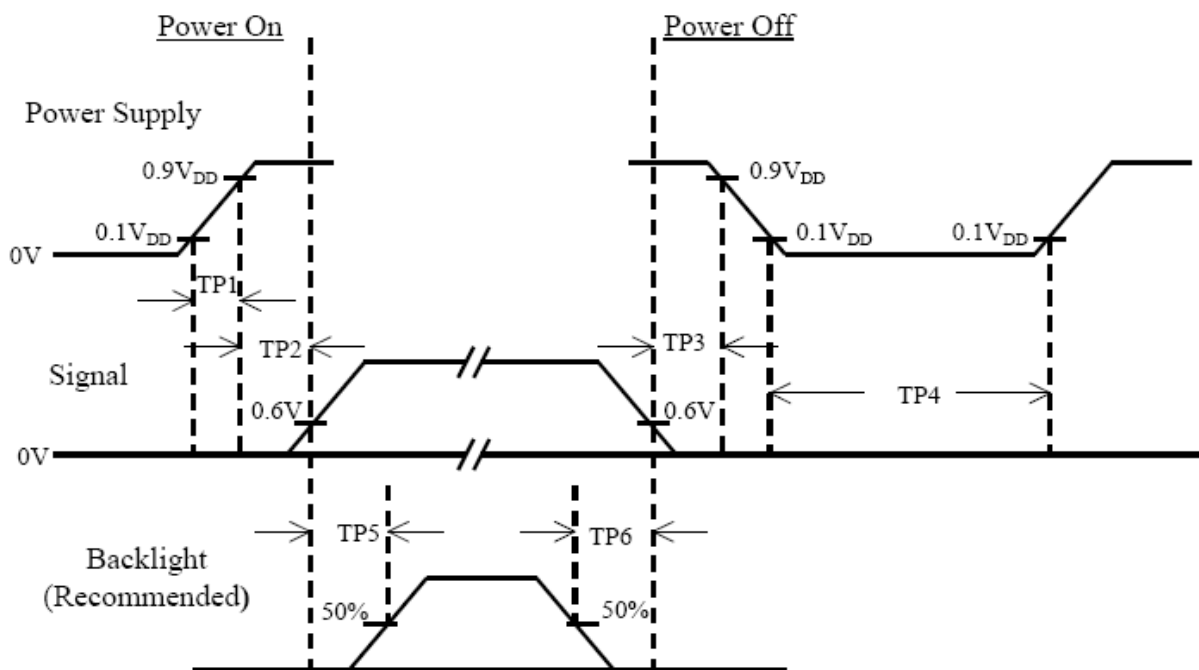

Item	Min.	Typ.	Max.	Unit	Remark
TP1	0.5	--	10	msec	
TP2	0	--	50	msec	
TP3	0	--	50	msec	
TP4	500	--	--	msec	
TP5	200	--	--	msec	
TP6	200	--	--	msec	

Note :

- (1) The supply voltage of the external system for the module input should be the same as the definition of VCC.
- (2) Apply the lamp voltage within the LCD operation range. When the back-light turns on before the LCD operation or the LCD turns off before the back-light turns off, the display may momentarily become white.
- (3) In case of VCC = off level, please keep the level of input signal on the low or keep a high impedance.
- (4) TP4 should be measured after the module has been fully discharged between power off and on period.
- (5) Interface signal shall not be kept at high impedance when the power is on.

# 7. DISPLAYED COLOR AND INPUT DATA

## DATA SIGNAL

COLOR		INPUT DATA																							
		R DATA								G DATA								B DATA							
		R7	R6	R5	R4	R3	R2	R1	R0	G7	G6	G5	G4	G3	G2	G1	G0	B7	B6	B5	B4	B3	B2	B1	B0
		MSB							LSB	MSB							LSB	MSB							LSB
BASIC COLOR	BLACK	0	0	0	0	0	0	0	0	0	0	0	0	0	0	0	0	0	0	0	0	0	0	0	0
	RED(255)	1	1	1	1	1	1	1	1	0	0	0	0	0	0	0	0	0	0	0	0	0	0	0	0
	GREEN(255)	0	0	0	0	0	0	0	0	1	1	1	1	1	1	1	1	0	0	0	0	0	0	0	0
	BLUE(255)	0	0	0	0	0	0	0	0	0	0	0	0	0	0	0	0	1	1	1	1	1	1	1	1
	CYAN	0	0	0	0	0	0	0	0	1	1	1	1	1	1	1	1	1	1	1	1	1	1	1	1
	MAGENTA	1	1	1	1	1	1	1	1	0	0	0	0	0	0	0	0	1	1	1	1	1	1	1	1
	YELLOW	1	1	1	1	1	1	1	1	1	1	1	1	1	1	1	1	0	0	0	0	0	0	0	0
	WHITE	1	1	1	1	1	1	1	1	1	1	1	1	1	1	1	1	1	1	1	1	1	1	1	1
RED	RED(1)	0	0	0	0	0	0	0	1	0	0	0	0	0	0	0	0	0	0	0	0	0	0	0	0
	RED(2)	0	0	0	0	0	0	1	0	0	0	0	0	0	0	0	0	0	0	0	0	0	0	0	0
	RED(255)	1	1	1	1	1	1	1	1	0	0	0	0	0	0	0	0	0	0	0	0	0	0	0	0
GREEN	GREEN(1)	0	0	0	0	0	0	0	0	0	0	0	0	0	0	0	1	0	0	0	0	0	0	0	0
	GREEN(2)	0	0	0	0	0	0	0	0	0	0	0	0	0	0	1	0	0	0	0	0	0	0	0	0
	GREEN(255)	0	0	0	0	0	0	0	0	1	1	1	1	1	1	1	1	0	0	0	0	0	0	0	0
BLUE	BLUE(1)	0	0	0	0	0	0	0	0	0	0	0	0	0	0	0	0	0	0	0	0	0	0	0	1
	BLUE(2)	0	0	0	0	0	0	0	0	0	0	0	0	0	0	0	0	0	0	0	0	0	0	1	0
	BLUE(255)	0	0	0	0	0	0	0	0	0	0	0	0	0	0	0	0	1	1	1	1	1	1	1	1

## 9. RELIABILITY TEST ITEMS

Test Item	Test Conditions	Note
High Temperature Operation	70±3°C , t=240 hrs	
Low Temperature Operation	-20±3°C , t=240 hrs	
High Temperature Storage	80±3°C , t=240 hrs	1,2
Low Temperature Storage	-30±3°C , t=240 hrs	1,2
Storage at High Temperature and Humidity	60°C, 90% RH , 240 hrs	1,2
Thermal Shock Test	-20°C (30min) ~ 70°C (30min) 100 cycles	1,2
Vibration Test (Packing)	Sweep frequency : 10 ~ 55 ~ 10 Hz/1min Amplitude : 0.75mm Test direction : X.Y.Z/3 axis Duration : 30min/each axis	2

Note(1) Condensation of water is not permitted on the module.

Note(2) The module should be inspired after 1 hour storage in normal conditions (15~35 °C, 45~65%RH).

Note(3) The module shouldn't be tested over one condition, and all the tests are independent.

Note(4) All reliability tests should be done without the protective film.

Definitions of life end point:

- Current drain should be smaller than the specific value.
- Function of the module should be maintained.
- Appearance and display quality should not have degraded noticeably.
- Contrast ratio should be greater than 50% of initial value.

## **10.USE PRECAUTIONS**

### **10.1 Handling precautions**

- 1) The polarizing plate may break easily so be careful when handling it. Do not touch, press or rub it with a hard-material tool like tweezers.
- 2) Do not touch the polarizing plate surface with bare hands so as not to make it dirty. If the surface or other related part of the polarizing plate is dirty, soak a soft cotton cloth or chamois leather in benzene and wipe off with it. Do not use chemical liquids such as acetone, toluene and isopropyl alcohol. Failure to do so may bring chemical reaction phenomena and deteriorations.
- 3) Remove any spit or water immediately. If it is left for hours, the suffered part may deform or decolorize.
- 4) If the LCD element breaks and any LC stuff leaks, do not suck or lick it. Also if LC stuff is stuck on your skin or clothing, wash thoroughly with soap and water immediately.

### **10.2 Installing precautions**

- 1) The PCB has many ICs that may be damaged easily by static electricity. To prevent breaking by static electricity from the human body and clothing, earth the human body properly using the high resistance and discharge static electricity during the operation. In this case, however, the resistance value should be approx.  $1M\Omega$  and the resistance should be placed near the human body rather than the ground surface. When the indoor space is dry, static electricity may occur easily so be careful. We recommend the indoor space should be kept with humidity of 60% or more. When a soldering iron or other similar tool is used for assembly, be sure to earth it.
- 2) When installing the module and ICs, do not bend or twist them. Failure to do so may crack LC element and cause circuit failure.
- 3) To protect LC element, especially polarizing plate, use a transparent protective plate (e.g., acrylic plate, glass etc) for the product case.
- 4) Do not use an adhesive like a both-side adhesive tape to make LCD surface (polarizing plate) and product case stick together. Failure to do so may cause the polarizing plate to peel off.

### **10.3 Storage precautions**

- 1) Avoid a high temperature and humidity area. Keep the temperature between  $0^{\circ}\text{C}$  and  $35^{\circ}\text{C}$  and also the humidity under 60%.
- 2) Choose the dark spaces where the product is not exposed to direct sunlight or fluorescent light.
- 3) Store the products as they are put in the boxes provided from us or in the same conditions as we recommend.

#### **10.4 Operating precautions**

- 1) Do not boost the applied drive voltage abnormally. Failure to do so may break ICs. When applying power voltage, check the electrical features beforehand and be careful. Always turn off the power to the LC module controller before removing or inserting the LC module input connector. If the input connector is removed or inserted while the power is turned on, the LC module internal circuit may break.
- 2) The display response may be late if the operating temperature is under the normal standard, and the display may be out of order if it is above the normal standard. But this is not a failure; this will be restored if it is within the normal standard.
- 3) The LCD contrast varies depending on the visual angle, ambient temperature, power voltage etc. Obtain the optimum contrast by adjusting the LC drive voltage.
- 4) When carrying out the test, do not take the module out of the low-temperature space suddenly. Failure to do so will cause the module condensing, leading to malfunctions.
- 5) Make certain that each signal noise level is within the standard (L level: 0.2VCC or less and H level: 0.8VCC or more) even if the module has functioned properly. If it is beyond the standard, the module may often malfunction. In addition, always connect the module when making noise level measurements.
- 6) The CMOS ICs are incorporated in the module and the pull-up and pull-down function is not adopted for the input so avoid putting the input signal open while the power is ON.
- 7) The characteristic of the semiconductor element changes when it is exposed to light emissions, therefore ICs on the LCD may malfunction if they receive light emissions. To prevent these malfunctions, design and assemble ICs so that they are shielded from light emissions.
- 8) Crosstalk occurs because of characteristics of the LCD. In general, crosstalk occurs when the regularized display is maintained. Also, crosstalk is affected by the LC drive voltage. Design the contents of the display, considering crosstalk.

#### **10.5 Other**

- 1) Do not disassemble or take the LC module into pieces. The LC modules once disassembled or taken into pieces are not the guarantee articles.
- 2) Do not keep the LCD at the same display pattern continually. The residual image will happen and it will damage the LCD. Please use screen saver.
- 3) AMIPRE will provide one year warranty for all products and three months warranty for all repairing products.

# 11. OUTLINE DIMENSION

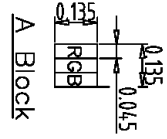

CN3	
1	VDD
2	YD+
3	GND
4	IND-
5	IND+
6	GND
7	IN1+
8	IN1-
9	IN2+
10	IN2-
11	CLK+
12	CLK-
13	VEED
14	ADU

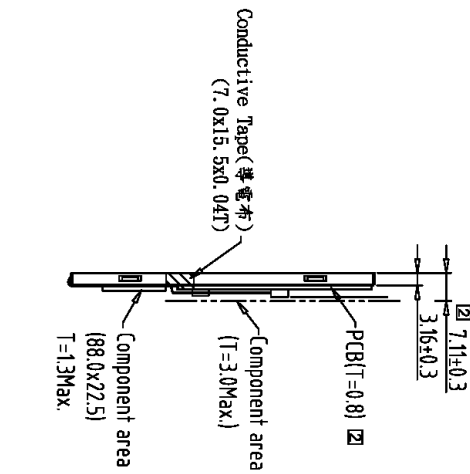
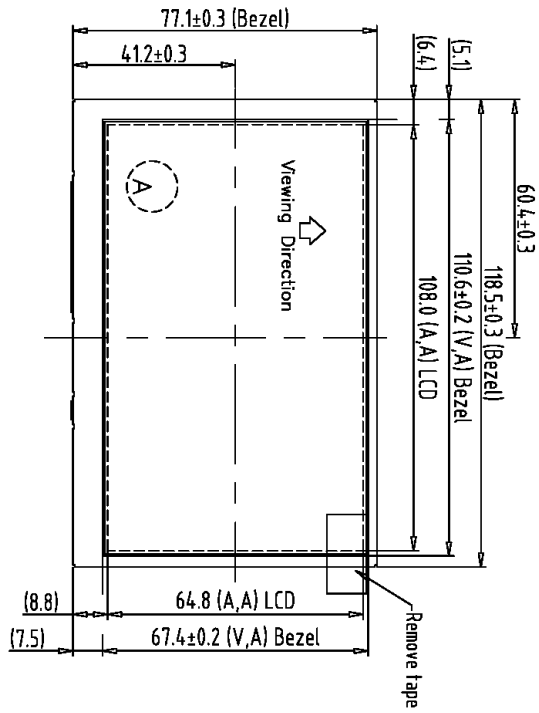

- Note:
1. Unless indicated, Tolerance "±0.3"
  2. UV Glue For OLB Protection.
  3. LCD 800x480 (R.G.B) TFT LCD => 5.0" TFT LCD
  4. CN3 Connector: P1.0x20Pin CP100-S20G-H16/DF-19G-20P-1H or Equivalent

REV	DESCRIPTION	DATE	BY	CHK	APPD.	DATE
0	NEW RELEASE	09-30-16				
1	Modify Interface	DATE				
2	Modify PCB (800,480,6-A2 to 800,480-A0)	DATE				

REV	DESCRIPTION	DATE	BY	CHK	APPD.	DATE
0	NEW RELEASE	09-30-16				
1	Modify Interface	DATE				
2	Modify PCB (800,480,6-A2 to 800,480-A0)	DATE				

REV	DESCRIPTION	DATE	BY	CHK	APPD.	DATE
0	NEW RELEASE	09-30-16				
1	Modify Interface	DATE				
2	Modify PCB (800,480,6-A2 to 800,480-A0)	DATE				

REV	DESCRIPTION	DATE	BY	CHK	APPD.	DATE
0	NEW RELEASE	09-30-16				
1	Modify Interface	DATE				
2	Modify PCB (800,480,6-A2 to 800,480-A0)	DATE				



REV	REVISION RECORD	DATE	NAME
0	NEW RELEASE	10-30-16	SNOW
1	Modify Interface	11-24-16	SNOW
2	Modify PCB (800480L6-A2 to 800480L-A0)	12-08-16	SNOW

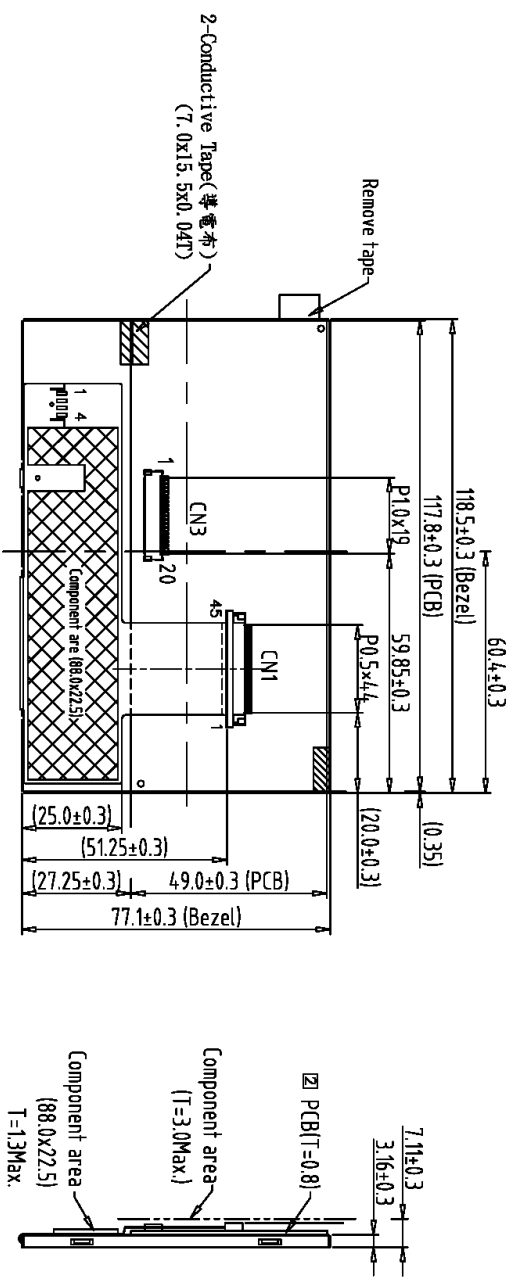

CN3		12	
1	VDD	11	IN2-
2	VDD	12	IN2+
3	GND	13	GND
4	GND	14	CLK-
5	INO-	15	CLK+
6	INO+	16	GND
7	GND	17	VLED
8	IN1-	18	VLED
9	IN1+	19	GND
10	GND	20	ADJ

Back view

- Note:
1. Unless indicated, Tolerance "±0.3"
  2. UV Glue For OLB Protection.
  3. LCD 800x480 (R.G.B) TFT LCD => 5.0" TFT LCD
  4. CN3 Connector: P1.0x20Pin CP100-S20G-H16/DF-19G-20P-1H or Equivalent

1	500nits / 30K	7	TOLERANCE GRADIENT		A	B	DIM.		DWG. SNOW	DATE
2	800480AZ+ 800480L-A0 PCB	8					MM		CHK.	09-30-16
3		9						IE NO.		DATE
4		10						PARTS NO. ICM-1		DATE
5		11						800480AZ-05	APPD.	
6		12								
										DWG. NO. *16097BMC
										SHEET 1 OF 1

**AWM**  
AMPIRE 晶采光电科技

800480AZ-05  
(5.0")